

DOUTHITT

TAKE THE "X" TEST

DO YOU HAVE LONG DELAYS
DUE TO SLOW CONTACT IN
YOUR VACUUM FRAME OR
PLATEMAKER?

ARE YOU EXPERIENCING
REGISTRATION PROBLEMS DUE
TO YOUR VACUUM FRAME OR
PLATEMAKER BEING
INCONSISTENT?

ARE YOU FIGHTING WASTE
AND MAKEOVERS IN YOUR PLATE
OR CONTACT ROOM?

IF YOU HAVE ANSWERED YES
TO ANY OF THE ABOVE – TALK
TO **DOUTHITT** ABOUT **OPTION "X"**.

DOUTHITT GUARANTEES: FASTEST CONTACT AND PERFECT REGISTRATION

OPTION "X" is a controlled inverse air evacuation system which starts the evacuation of air in the center of the frame and then moves outward to the edges eliminating the trapping of air. It is over twice as fast as a conventional frame and quickly pays for itself in time saved and avoidance of remakes.

- Only Douthitt has a spring loaded vacuum system allowing you to use pins of any height, pin bars or contact boards of any thickness
- Because of its absolute, consistent, repeatable electronically controlled air evacuation pattern, it will maintain better register than any other frame and will reduce your makeovers and scrap rate
- Fastest contact on the market **guaranteed**
- Reduces makeovers and waste in the contact and plateroom
- truly the STATE-OF-THE-ART vacuum frame

With these outstanding features added to the rugged well built Heavy Duty Douthitt units – you get the **BEST** and it **PAYS** for itself in a FEW months.

We will be happy to review your needs – Call us on our toll free number

1-800-DOUTHIT(T)

Fax No. 1-313-259-6806

G.A.T.F. AWARDS DOUTHITT

InterTech Technology Award

For its Development of Option "X" Vacuum Frames

DOUTHITT HEAVY DUTY CONSOLE OVERHEAD PLATEMAKER

ALL DOUTHITT PLATEMAKERS NOW COME STANDARD WITH OPTION "X"



Ideal For

- Plates •
- Proofs •
- Films •
- Flexographic Plates

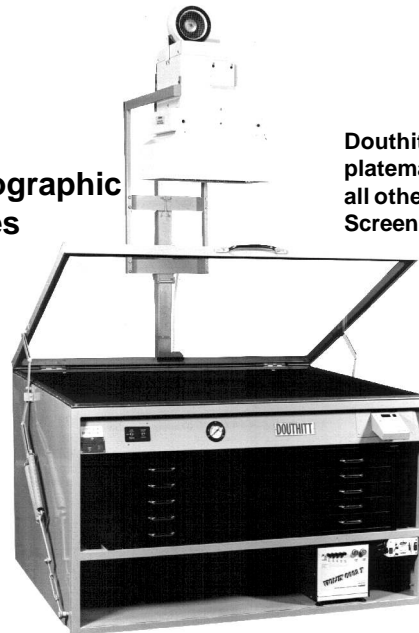

Douthitt Option "X" platemakers outperform all other for Stochastic Screening.

PRICE INCLUDES:

- (1) Douthitt's OPTION "X" Vacuum system, an electronically controlled inverse air evacuation system that starts the vacuum in the center of the frame and moves it outward to the edges eliminating the trapping of air. OPTION "X" gives you the fastest, most consistent overall contact and the best registration. For more details on OPTION "X" see page 2.
- (2) Complete Olite AL 53 Tri-Level 5000 Watt Printing Lamp Assembly. For more details on the Olite and Violux Printing Lamps see pages 8-9.
- (3) Douthitt Heavy Duty Model Magic 83 Combination Light Integrator and Digital Timer with 10 channel memory. Integrator comes complete with vacuum time delay, PA 86 dual UV photocell, and ability to control all 3 intensities of printing lamps. For more details see page 10.
- (4) Printing Lamp can be raised and lowered by means of counterbalanced weight concealed in vertical post.
- (5) Spring Loaded Back is furnished on the blanket frame allowing any height register pins or contact boards of any thickness.

DOUTHITT'S NEW VACUUM SYSTEM

OPTION "X" Patented & Pat. Pending

OPTION "X" is a controlled inverse air evacuation system which starts the evacuation of air in the center of the frame and then moves outward to the edges eliminating the trapping of air. It is over twice as fast as a conventional frame and quickly pays for itself in time saved and avoidance of remakes. Because of its absolute, consistent, repeatable electronically controlled air evacuation pattern, it will maintain better register than any other frame and will reduce your makeovers and scrap rate.

- (6) Printing Lamp has travel up to 60" for daylight materials.
- (7) Easy to see "Read Out" in one-inch multiples gives accurate positioning of distance between lamp and frame.
- (8) Heavy Duty Vacuum Pump and Motor.
- (9) Heavy Duty Universal Blanket.
- (10) Finger Tip Control of glass frame is achieved by exclusive, patented spring and fulcrum system (clamps automatically).
- (11) Optic clear A-1 Select Glass.
- (12) Power Supply and Pump and Motor are housed on shelf inside Frame.
- (13) All heavy gauge steel welded construction.
- (14) Vacuum Gauge, Integrator and necessary operational switches housed on convenient instrument panel.
- (15) Floor type adjustable leveling screws.

DOUTHITT HEAVY DUTY CONSOLE OVERHEAD PLATEMAKER

**ONLY DOUTHITT HAS A SPRING LOADED VACUUM SYSTEM ALLOWING YOU TO USE
PINS OF ANY HEIGHT, PIN BARS OR CONTACT BOARDS OF ANY THICKNESS**

Film and Plate Size	Size Inside Blanket Beading	Price with OPTION "X"	Crating	Floor Space	Height*	Approx. Crated Weight	Minimum and Maximum Printing Distance
							Between Frame and Lamp (measured from edge of Reflector) in one inch increments
30 x 40	31 x 41	\$12,095.00	No Chg.	40 x 47	8'8"	1250 lbs.	24" thru 60"
35 x 45	37 x 47	\$12,625.00	No Chg.	47 x 55	8'8"	1350 lbs.	24" thru 60"
40 x 50	42 x 52	\$12,975.00	No Chg.	53 x 60	8'8"	1450 lbs.	24" thru 60"
44 x 54	46 x 55	\$13,425.00	No Chg.	57 x 64	8'8"	1500 lbs.	24" thru 60"
40 x 60	42 x 62	\$13,525.00	No Chg.	53 x 70	8'8"	1550 lbs.	30" thru 60"
48 x 60	51 x 63	\$13,995.00	No Chg.	61 x 70	8'8"	1650 lbs.	30" thru 60"

*Height dimension is from floor to top of post. If Olite Lamp is ordered add eleven inches to height dimension for maximum distance. If Violux Lamp is ordered add twenty-four inches. Special heights for low ceiling – details on request. Electrical – 115 Volt, 60 hz. Single Phase A.C. Vacuum System. 220 Volt, 60 hz. Single Phase A.C. Lamp.

OPTIONAL ACCESSORIES:

- | | |
|---|--|
| <p>(A) Douthitt Heavy Duty Model 26 Silent Air Pump instead of standard pump and motor (this pump requires compressed air) see page 27 for details Add \$ 395.00</p> <p>(B) Any Douthitt or Olix Combination Light Integrator and Digital Timer can be mounted in lieu of Standard Integrator Olix 975SC Add \$ 445.00</p> <p>(C) Olite AL 83 8000 Watt Tri-Level Printing Lamp Assembly complete with exhaust system instead of Standard Lamp Add \$1495.00</p> <p>(D) Filters for Olite Lamps
Dual Rolling Filter Holder with Kokomo and Clearing Filter Add \$ 695.00
Motorized Dual Rolling Filter Holder with Kokomo and Clearing Filter (special integrator is needed for automation) Add \$1180.00</p> <p>(E) Violux VT6 6000 Watt Tri-Level Printing Lamp Assembly instead of Standard Lamp Add \$ 295.00</p> <p>(F) Violux VT8 8000 Watt Tri-Level Printing Lamp Assembly instead of Standard Lamp Add \$1095.00</p> | <p>(G) Filters for Violux Lamps
Double Rail extended Mounting Brackets with Kokomo and Clearing Filters Add \$ 695.00
Motorized Dual Rolling Filter Holder with Kokomo and Clearing Filter Add \$1495.00 (special integrator is needed for automation)</p> <p>(H) Opaque Curtain Assembly – Eliminate Light Spillage, Fully Fire Retardant and OSHA approved material Add \$1095.00 (Curtain assemblies ordered separately add \$100.00)</p> <p>(I) Designed to be used with Central Vacuum System instead of Standard Pump and Motor N/C</p> <p>(J) 5-Drawer Ball Bearing Cabinet mounted inside frame 30 x 40 (Drawer I.D. 25 x 37) \$ 995.00
35 x 45 and 40 x 50 (Drawer I.D. 32 x 43) \$1095.00
44 x 54 through 48 x 60 (Drawer I.D. 38 x 50) . \$1195.00
Larger cabinets available.</p> <p>(K) Your choice of color (If not specified the unit will be finished in an easy to clean long wearing gray epoxy enamel) N/C</p> <p>(L) Motorized Diffusion Filter over glass frame for Flexographic Plates (reduces film and plate size by 5" left to right) Special integrator is needed for automation Add \$ 3495.00</p> <p>(M) Convenient Yellow Inspection Light mounted on Lamp Carriage Assembly Add \$ 225.00</p> |
|---|--|

DOUTHITT HEAVY DUTY VACUUM FRAME LARGE BENCH MODEL

**NOW STANDARD WITH OPTION "X"
FASTEST CONTACT • BEST REGISTRATION**

PRICE INCLUDES:

- (1) Douthitt's OPTION "X" Vacuum System. OPTION "X" gives you the fastest, most consistent overall contact and the best registration. For details see page 2.
- (2) Finger-Tip Counterbalanced control of this unit is achieved by the Douthitt "Exclusive, Patented, Spring and Fulcrum System".
- (3) Heavy Duty Vacuum Pump and Motor.
- (4) Heavy Duty SMOOTH Universal Blanket.
- (5) No External Locking Device.
- (6) Optic clear A-1 Select Glass.
- (7) Ten Foot Service Cord.
- (8) All heavy gauge steel welded construction.
- (9) Vacuum Gauge and On-Off Toggle Switch.
- (10) Unit finished in easy to clean, long wearing Epoxy Enamel.
- (11) Spring Loaded Back is furnished on the blanket frame allowing any height register pins or contact boards of any thickness.
- (12) Adjustable Leveling Screws.

Larger or Smaller Frames available – Prices on request.

Electrical Specifications – 115 Volt, 60 Cycle, Single Phase, A.C. Special Electrical requirements available on request.



Film and Plate Size	Size Inside Blanket Beading	Price with OPTION "X"	Space Required	Crating No Chg. Weight
26 x 30	27 x 31	\$3795.00	32 x 37	340 lbs.
30 x 40	31 x 41	\$4175.00	36 x 49	360 lbs.
33 x 43	35 x 45	\$4275.00	40 x 53	370 lbs.
37 x 48	38 x 50	\$4545.00	43 x 58	390 lbs.
40 x 50	42 x 52	\$4645.00	47 x 60	420 lbs.
40 x 60	42 x 62	\$5045.00	47 x 70	530 lbs.
48 x 60	50 x 62	\$5425.00	58 x 71	580 lbs.

DOUTHITT'S NEW VACUUM SYSTEM OPTION "X" Patented & Pat. Pending

OPTION "X" is a controlled inverse air evacuation system which starts the evacuation of air in the center of the frame and then moves outward to the edges eliminating the trapping of air. It is over twice as fast as a conventional frame and quickly pays for itself in time saved and avoidance of remakes. Because of its absolute, consistent, repeatable electronically controlled air evacuation pattern, it will maintain better register than any other frame and will reduce your makeovers and scrap rate.

OPTIONAL ACCESSORIES:

- | | |
|---|--|
| <p>(A) Douthitt Heavy Duty Model 26 Silent Air Pump instead of standard pump and motor (this pump requires compressed air) see page 27 for details Add \$ 395.00</p> <p>(B) Any Douthitt or Olix Combination Light Integrator and Digital Timer can be mounted in front instrument panel.
MAGIC 83 with PA 86 photocell Add \$ 870.00
Olix 975SC with PA 86 photocell Add \$1130.00
Details on page 10.
(Vacuum time delay is included with any of above integrators)</p> <p>(C) Registration Board or Insert Mat manufactured to your specifications Prices upon request</p> | <p>(D) Frame may be ordered without OPTION "X" Prices upon request</p> <p>(E) Heavy Duty Tubular Steel Stand, which can be disassembled for easy access.
26 x 30 thru 33 x 43 Add \$ 200.00
37 x 48 and 40 x 50 Add \$ 250.00
40 x 60 and 48 x 60 Add \$ 300.00</p> <p>(F) 5-Drawer Ball Bearing Cabinet mounted inside above stand.
30 x 40 and 33 x 43 (Drawer I.D. 25 x 37) Add \$ 995.00
37 x 48 and 40 x 50 (Drawer I.D. 32 x 43) Add \$1095.00
40 x 60 and 48 x 60 (Drawer I.D. 38 x 50) Add \$1195.00
(This option can only be ordered if you are ordering Option E.)</p> |
|---|--|

DOUTHITT HEAVY DUTY VACUUM FRAME LARGE BENCH ON STAND MODEL

PRICE INCLUDES:

- (1) Douthitt's OPTION "X" Vacuum System. OPTION "X" gives you the fastest, most consistent overall contact and the best registration. For details see page 2.
- (2) Finger-Tip Counterbalanced control of this unit is achieved by the Douthitt "Exclusive, Patented, Spring and Fulcrum System".
- (3) Heavy Duty Vacuum Pump and Motor.
- (4) Heavy Duty SMOOTH Universal Blanket.
- (5) No External Locking Device.
- (6) Optic clear A-1 Select Glass.
- (7) Ten Foot Service Cord.
- (8) All heavy gauge steel welded construction.
- (9) Vacuum Gauge and On-Off Toggle Switch.
- (10) Unit finished in easy to clean, long wearing Epoxy Enamel.
- (11) Spring Loaded Back is furnished on the blanket frame allowing any height register pins or contact boards of any thickness.
- (12) Adjustable Leveling Screws.

Larger Frames available – Prices on request.

Electrical Specifications – 115 Volt, 60 Cycle, Single Phase, A.C.

Special Electrical requirements available on request.



**NOW STANDARD
WITH OPTION "X"
FASTEST CONTACT •
BEST REGISTRATION**

Film and Plate Size	Size Inside Blanket Beading	Price with OPTION "X"	Floor Space	Crating No Chg. Weight
26 x 30	27 x 31	\$3975.00	32 x 38	410 lbs.
30 x 40	31 x 41	\$4375.00	36 x 48	480 lbs.
33 x 43	35 x 45	\$4475.00	40 x 52	500 lbs.
37 x 48	38 x 50	\$4775.00	43 x 57	540 lbs.
40 x 50	42 x 52	\$4895.00	47 x 59	570 lbs.
40 x 60	42 x 62	\$5345.00	47 x 69	610 lbs.
48 x 60	50 x 62	\$5725.00	58 x 70	700 lbs.

DOUTHITT'S NEW VACUUM SYSTEM OPTION "X" Patented & Pat. Pending

OPTION "X" is a controlled inverse air evacuation system which starts the evacuation of air in the center of the frame and then moves outward to the edges eliminating the trapping of air. It is over twice as fast as a conventional frame and quickly pays for itself in time saved and avoidance of remakes. Because of its absolute, consistent, repeatable electronically controlled air evacuation pattern, it will maintain better register than any other frame and will reduce your makeovers and scrap rate.

OPTIONAL ACCESSORIES:

- (A) Douthitt Heavy Duty Model 26 Silent Air Pump instead of standard pump and motor (this pump requires compressed air) see page 27 for details Add \$ 395.00
- (B) Any Douthitt or Olix Combination Light Integrator and Digital Timer can be mounted in front instrument panel.
MAGIC 83 with PA 86 photocell Add \$ 870.00
Olix 975SC with PA 86 photocell..... Add \$1130.00
Details on page 10.
(Vacuum time delay is included with any of above integrators)
- (C) Opaque Curtain – Eliminate Light Spillage. Fully Fire retardant and OSHA approved Material \$1195.00
- (D) Registration Board or Insert Mat manufactured to your specifications Prices upon request
- (E) Adjustable Post complete with 1000 Watt Quartz Light or 100 Watt Point Light Add \$1495.00

- (F) Motorized Diffusion Filter over the glass frame for cutlines, chokes and spreads (reduces film size by 5" left to right) – Special integrator is needed for automation.

Prices on request

Unit shown with heavy duty Tubular steel stand (page 6) Option (E))



- (G) Frame may be ordered without OPTION "X" Prices upon request

VIOLUX AND OLITE PRINTING LAMPS

BEST SELECTION OF THE WORLD'S FINEST PRINTING LAMPS

**SAME DAY DELIVERY FROM DOUTHITT WAREHOUSE
(FACTORY AUTHORIZED SALES AND SERVICE)**

VIOLUX LAMP ASSEMBLIES

MODEL	SPECIFICATIONS	PRICE
VT4	VIOLUX 4002T Tri-Level 4000 Watt Printing Lamp Assembly (4000-2000-1000) Maximum Current: 25 amps Shipping Weight: 220 lbs.	\$4095.00
VT6	VIOLUX 6002T Tri-Level 6000 Watt Printing Lamp Assembly (6000-3000-1500) Maximum Current: 40 amps Shipping Weight: 235 lbs.	\$4695.00
VT8	VIOLUX 8002T Tri-Level 8000 Watt Printing Lamp Assembly (8000-4000-2000) Maximum Current: 50 amps Shipping Weight: 240 lbs.	\$5695.00

ELECTRICAL SPECIFICATIONS ON VIOLUX HIGH WATTAGE LAMPS 190-250 V/1/A.C.

Lamps can be ordered with a stand for vertical printing Add \$ 450.00

	Part No.	Price		Part No.	Price
FOR VIOLUX 500S and/or 1500			FOR VIOLUX SUPER/MULTI 10/8002T		
Multi Spectrum, type THS1507	823197	\$160.00	Multi Spectrum, type THS8027	821897	\$365.00
FOR VIOLUX 3002/4002T			FOR VIOLUX RAPID		
Diazo, type THS3020	822390	\$195.00	Diazo, type 5090	34299	\$260.00
Multi Spectrum, type THS3027	821397	\$195.00	FOR VIOLIGHT 1000		
FOR VIOLUX VM4			Diazo, type THS1000	820190	\$160.00
Diazo, type THS4020	822490	\$225.00	Multi Spectrum, type THS1007	820197	\$160.00
Multi Spectrum, type THS4027	822497	\$225.00	FOR VIOLIGHT 3000		
FOR VIOLUX 5002			Diazo, type THS3000	820390	\$165.00
Diazo, type THS5020	822590	\$265.00	Multi Spectrum, type THS3007	820397	\$165.00
Multi Spectrum, type THS5027	822597	\$265.00	FOR VIOLIGHT 5000		
FOR VIOLUX VM6/6002T			Diazo, type THS5000	820590	\$260.00
Diazo, type THS6020	822690	\$270.00	Multi Spectrum, type THS5007	820597	\$260.00
Multi Spectrum, type THS6027	822697	\$270.00			

OPTIONAL ACCESSORIES:

For High Wattage Lamps

- | | | | | | |
|---|--|----------|---|--|---------------|
| (A) Kokomo Filter | | | (D) Extended Double Rail Mounting Bracket for Filters | | |
| with mounting brackets | | \$295.00 | (for overhead mounted systems) | | \$255.00 |
| without mounting brackets | | \$235.00 | (E) Extended Double Rail Mounting Bracket for Filters | | |
| (B) Dylux Clearing Filter complete | | | (for stand mounted systems) | | \$395.00 |
| with mounting brackets | | \$295.00 | (F) Extended Triple Rail Mounting Bracket for Filters | | |
| without mounting brackets | | \$235.00 | (for overhead mounted systems) | | \$495.00 |
| (C) Attenuator Filter (less tint) | | \$235.00 | (G) Motorized Dual Rolling Filter Holder with | | |
| | | | Kokomo and Clearing Filter (Special | | |
| | | | integrator is needed for automation) | | Add \$1595.00 |

OLITE AND VIOLUX PRINTING LAMPS

**SAME DAY DELIVERY FROM DOUTHITT WAREHOUSE
(FACTORY AUTHORIZED SALES AND SERVICE)**

OLITE LAMP ASSEMBLIES

MODEL	SPECIFICATIONS	PRICE
AL13	OLITE Printing Lamp Assembly, Tri-Level 900 Watt (900-650-400) Electrical: 115 Volt, Single Phase, 9 amps maximum operating current Shipping Weight: 35 lbs.	\$1715.00
AL19/AL20	OLITE Printing Lamp Assembly, Tri-Level 1900 Watt (1900-1300-600) Electrical: AL19 115 Volt, Single Phase, 20 amps maximum operating current AL20 220 Volt, Single Phase, 10 amps maximum operating current Shipping Weight: 70 lbs.	\$2430.00
AL23	OLITE Printing Lamp Assembly, Tri-Level 2300 Watt (2300-1600-1000) Electrical: 220 Volt, Single Phase, 12 amps maximum operating current Shipping Weight: 75 lbs.	\$2935.00
AL35	OLITE Printing Lamp Assembly, Tri-Level 3500 Watt (3500-2000-900) Electrical: 220 Volt, Single Phase, 16 amps maximum operating current Shipping Weight: 175 lbs.	\$3670.00
AL53	OLITE Printing Lamp Assembly, Tri-Level 5000 Watt (5000-2000-1000) Electrical: 220 Volt, Single Phase, 23 amps maximum operating current Shipping Weight: 200 lbs.	\$4720.00
AL83*	OLITE Printing Lamp Assembly, Tri-Level 8000 Watt (8000-3500-2000) Electrical: 220 Volt, Single Phase, 42 amps maximum operating current Shipping Weight: 200 lbs. *HF1 Exhaust System recommended with AL83..... Add \$ 495.00	\$5665.00

REPLACEMENT BULBS FOR OLITE LAMPS

FOR AL9/AL13

L900	Multi Spectrum Lamp	\$195.00
L902	Photopolymer Lamp	\$195.00

FOR AL15

L1150A	Photopolymer Lamp	\$250.00
L1150B	Diazo Lamp	\$250.00

FOR AL19/AL20

L1250E	Dual Spectrum Lamp	\$325.00
L1150A	Photopolymer Lamp	\$250.00

FOR AL35/53/100* LAMPS (*Two required for AL100)

L1250	Dual Spectrum Lamp	\$275.00
L1261	Photopolymer Lamp	\$275.00
L1252	Photopolymer /Diazo Lamp	\$325.00

FOR AL83 LAMP

L1280	Diazo Lamp	\$350.00
L1281	Photopolymer Lamp	\$350.00
L1282	Dual Spectrum Lamp	\$350.00

OPTIONAL ACCESSORIES:

FOR AL83/AL53/AL35/AL23/AL19/AL20 LAMPS:

	PRICE
(A) Filter Holder with either Kokomo or Clearing Filter	\$ 165.00
(B) Rolling Filter Holder with either Kokomo or Clearing Filter	\$ 560.00
(C) Dual Rolling Filter Holder with Kokomo and Clearing Filter	\$ 695.00
(D) Motorized Rolling Filter Holder with Kokomo or Clearing Filter	\$ 990.00
(E) Motorized Dual Rolling Filter Holder with Kokomo and Clearing Filter	\$1180.00
(F) Exhaust System.....	\$ 495.00
(G) Floor stand for vertical printing.....	\$ 290.00



Violux
VT6



Olite
AL53

DOUTHITT and OLIX INTEGRATORS

THE MOST COMPLETE SELECTION OF THE WORLD'S BEST COMBINATION LIGHT INTEGRATORS AND DIGITAL TIMERS

Quality demands control and consistency. Light source variations affect the quality of your exposed film, plates, screens or proofs. With microprocessor technology these precision instruments automatically compensate for these variations by adjusting the length of the exposure to provide the correct amount of light every time. These integrators can also be set up to control vacuum draw down time to eliminate another variable.

DOUTHITT Model Magic 83 Combination Light Integrator and Digital Timer

Price with PA 86 UV photocell \$770.00

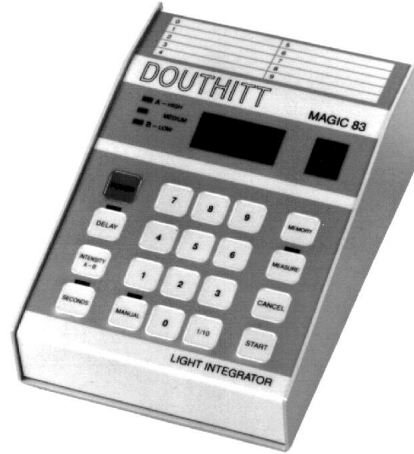

PRICE INCLUDES:

- (1) Ten (10) programmable memories.
- (2) Large, easy to read display that counts down and resets after each exposure.
- (3) Vacuum time delay.
- (4) Remote control of two lights or up to three intensity levels on Olec Printing Lamps.
- (5) Simple design for ease of operation.
- (6) Complete 15 foot photo cell. Unit can be ordered with different photo cells to better suit specific needs. See optional accessories.
- (7) Photometer.

OPTIONAL ACCESSORIES

1. PA 92 Q Photocell 15 ft.	\$125.00
2. PA 86 Dual Photocell, wide band UV filter for frame mounting	125.00
3. QXD Accessory Box (for vacuum time delay or 1000 Watt quartz light)	155.00
7. CIB Controlled Interface Box	175.00

OLIX Model 975SC

- Thirty-one Channels • Control of Filters
- Battery Back Up • Individual Vacuum Delays

Price with PA 86 UV photocell \$1020.00

DOUTHITT HEAVY DUTY PLATEMAKER

MODEL DCOPXD



- **DESIGNED TO LOOK ATTRACTIVE IN A NON TRADITIONAL ENVIRONMENT.**
- **BEST PERFORMANCE ON**
 - PLATES
 - PROOFS
 - FILMS
 - STOCHASTIC
- **OPTION "X" GUARANTEES FASTEST CONTACT AND BEST REGISTRATION**

Film and Plate Size	Size Inside Blanket Beading	Price with OPTION "X"	Crating	Floor Space	Height	Approx. Crated Weight	Minimum and Maximum Printing Distance Between Frame and Lamp (measured from edge of Reflector) in one inch increments
29 x 40	31 x 41	\$15,095.00	No Chg.	45 x 55	8'0"	1550 lbs.	24" thru 48"
35 x 45	37 x 47	\$15,595.00	No Chg.	51 x 61	8'0"	1650 lbs.	24" thru 48"
40 x 50	42 x 52	\$15,895.00	No Chg.	56 x 66	8'0"	1800 lbs.	24" thru 48"

PRICE INCLUDES:

- (1) Douthitt's OPTION "X" Vacuum system, and electronically controlled inverse air evacuation system that starts the vacuum in the center of the frame and moves it outward to the edges eliminating the trapping of air. OPTION "X" gives you the fastest, most consistent overall contact and the best registration. For more details on OPTION "X" see page 2.
- (2) Complete Olite AL53 Tri-Level 5000 Watt Printing Lamp Assembly. For more details on the Olite and Violux Printing Lamps see page 8-9.
- (3) Douthitt Heavy Duty Model Magic 83 Combination Light Integrator and Digital Timer with 10 channel memory. Integrator comes complete with vacuum time delay, PA 86 dual UV photocell, and ability to control all 3 intensities of printing lamps. For more details see page 10.
- (4) 5-Drawer Ball Bearing Cabinet mounted inside frame.
- (5) Opaque curtain assembly to eliminate light spillage. Fully fire retardant and OSHA approved material.
- (6) Printing Lamp can be raised and lowered by means of counterbalanced weight concealed in vertical post.
- (7) Spring Loaded Back is furnished on the blanket frame allowing any height register pins or contact boards of any thickness.
- (8) Finger Tip Control of glass frame is achieved by exclusive patented spring and fulcrum system (clamps automatically).
- (9) Heavy Duty Vacuum Pump and Motor.
- (10) Heavy Duty Universal Blanket.
- (11) All heavy gauge steel welded construction.
- (12) Floor type adjustable leveling screws.

DOUTHITT HEAVY DUTY TWIN FRAME PLATEMAKER

PRODUCTION SPEED

PRECISION QUALITY

MODEL GEMINI

- Load One Frame While Other Frame Is Exposing
- Option "X" On Both Frames Guarantees Fastest Contact And Best Registration
- Counterbalanced Adjustable Lamp To Optimize Exposure Time And Coverage



PRICE INCLUDES:

- (1) Two complete vacuum frames with the OPTION "X" cavity vacuum system, an electronically controlled inverse air evacuation system that starts the vacuum in the center of the frame and moves it outward to the edges eliminating the trapping of air. OPTION "X" gives you the fastest, most consistent overall contact and the best registration. For more details on OPTION "X" see page 2.
- (2) Complete Olite AL 53 Tri-Level 5000 Watt Printing Lamp Assembly. For more information on Olite and Violux Printing Lamps see page 8-9.
- (3) Two Douthitt Heavy Duty Magic 83 Combination Light Integrators and Digital Timers. Each integrator comes complete with PA 86 photocell. For more details see page 10.
- (4) Printing Lamp can be raised and lowered by means of counterbalanced weight concealed inside unit, guaranteeing optimum coverage.
- (5) Spring Loaded Back is furnished on both blanket frames allowing any height register pins or contact boards of any thickness.
- (6) Vacuum Frames are power driven on heavy duty gear track with precision bearings.
- (7) Electronically controlled accelerating and decelerating motor for smooth operation.
- (8) Conveniently located control switches and vacuum gauges.
- (9) Large access doors for easy cleaning, installation and maintenance.
- (10) All Heavy gauge steel welded construction.
- (11) Two Heavy Duty pump and motors.
- (12) Two Heavy Duty smooth universal blankets.
- (13) Pumps and Power Supply conveniently located on shelf inside cabinet.
- (14) Effortless raising and lowering of the glass frames.
- (15) Floor type adjustable level bolts.

DOUTHITT HEAVY DUTY TWIN FRAME PLATEMAKER MODEL GEMINI

**ONLY DOUTHITT HAS THE OPTION "X" VACUUM SYSTEM
TO GUARANTEE PERFECT REGISTRATION**

Film and Plate Size	Size Inside Blanket Beading	Price with OPTION "X"	Crating	Floor Space	Height*	Approx. Crated Weight	Minimum and Maximum Printing Distance
							(measured from edge of Reflector) in one inch increments
29 x 40	31 x 41	\$20,195.00	No Chg.	61 x 72	7'0"	2200 lbs.	25" thru 43"
35 x 45	37 x 47	21,295.00	No Chg.	67 x 83	7'0"	2600 lbs.	25" thru 43"
40 x 50	42 x 52	22,295.00	No Chg.	72 x 93	7'0"	3300 lbs.	25" thru 43"
44 x 54	46 x 56	23,595.00	No Chg.	76 x 101	7'0"	3700 lbs.	25" thru 43"
40 x 60	42 x 62	23,795.00	No Chg.	82 x 93	7'0"	3700 lbs.	25" thru 43"
48 x 60	51 x 63	25,195.00	No Chg.	84 x 114	7'4"	4000 lbs.	29" thru 47"

*Height dimension is to top of cabinet. If Olite Lamp is ordered, add 10" to height dimensions for maximum distance. If Violux Lamp is ordered, add twenty-four inches. Electrical – 220 Volt, Single Phase. **Gemini can be disassembled if needed for installation**

DOUTHITT'S NEW VACUUM SYSTEM OPTION "X" Patented & Pat. Pending

OPTION "X" is a controlled inverse air evacuation system which starts the evacuation of air in the center of the frame and then moves outward to the edges eliminating the trapping of air. It is over twice as fast as a conventional frame and quickly pays for itself in time saved and avoidance of remakes. Because of its absolute, consistent, repeatable electronically controlled air evacuation pattern, it will maintain better register than any other frame and will reduce your makeovers and scrap rate.

OPTIONAL ACCESSORIES:

- | | |
|---|---|
| <p>(A) Two Douthitt Heavy Duty Model 26 Silent Air Pump instead of standard pumps and motors (these pumps require compressed air) Add \$ 790.00</p> <p>(B) Any Douthitt or Olix Combination Light Integrators and Digital Timers can be mounted in lieu of standard integrators Olix 975SC Add \$ 945.00</p> <p>(C) Olite AL83 8000 Watt Tri-Level Printing Lamp Assembly with exhaust system instead of Standard Lamp Add \$1495.00</p> <p>(D) Filters for Olite Lamps Motorized Dual Rolling Filter Holder with Kokomo and Clearing Filters Add \$1180.00</p> <p>(E) Violux VT6 6000 Watt Tri-Level Printing Lamp Assembly instead of Standard Lamp Add \$ 295.00</p> | <p>(F) Violux VT8 8000 Watt Tri-Level Printing Lamp Assembly instead of Standard Lamp Add \$1095.00</p> <p>(G) Filters for Violux Lamps Motorized Dual Rolling Filter holder with Kokomo and Clearing Filters Add \$1495.00</p> <p>(H) Registration Board or Insert Mat manufactured to your specifications Prices upon request</p> <p>(I) 5-Drawer Ball Bearing Cabinet mounted inside frame 29 x 40 (Drawer I.D. 25 x 37) \$1145.00
35 x 45 and 40 x 50 (Drawer I.D. 32 x 43) \$1295.00
44 x 54 through 48 x 60 (Drawer I.D. 38 x 50) . \$1395.00
Larger cabinets available.</p> <p>(J) Motorized raising and lowering of Printing Lamp Assembly instead of manual lifting Add \$ 995.00</p> <p>(K) Spare bulb for printing lamp see pages 8 & 9.</p> |
|---|---|

DOUTHITT Elevating and Revolving Platemaker

ALL DOUTHITT PLATEMAKERS NOW COME STANDARD WITH OPTION "X"

PRICE INCLUDES:

- (1) Douthitt's OPTION "X" Vacuum system, an electronically controlled inverse air evacuation system that starts the vacuum in the center of the frame and moves it outward to the edges eliminating the trapping of air. OPTION "X" gives you the fastest, most consistent overall contact and the best registration. For more details on OPTION "X" see page 2.
- (2) Complete Violux VT6 6000 Watt Tri-Level Lamp Assembly. Available with choice of Diazo or Multi Spectrum bulb to exactly fit your needs. For more information of the Violux and Olite Printing Lamp see pages 8-9.
- (3) Douthitt Heavy Duty Model Magic 83 Combination Light Integrator and Digital Timer with 10 channel memory. Integrator comes complete with vacuum time delay, PA 86 dual UV photocell. For more details see page 10.
- (4) Fabricated Steel superstructure housing for the Printing Lamp.
- (5) Printing lamp is raised and lowered by means of power driven screw drive.
- (6) The power driven screw drive actuated by conveniently mounted push button station. Limit Switches are incorporated to prevent overtravel in either direction.
- (7) Easy to see "Read Out" in one-inch multiples gives accurate positioning of distance between lamp and frame.
- (8) Revolves 360° through Gyrotory Axis which Elevates, Lowers, Locks and Turns in single sweeping effortless action. See illustrations on page 16.
- (9) Can be elevated with glass up or down.
- (10) Minimizes time spent in cleaning glass.
- (11) Inspection Light (Gold Fluorescent) mounted in base and operated by independent switch allows viewing and inspection of work and assists in cleaning glass.
- (12) Spring Loaded Back is furnished on the blanket frame allowing any height register pins on top or thru register boards.
- (13) Heavy Duty Universal Blanket.
- (14) Heavy Duty Pump, Motor and Vacuum Gauge.
- (15) Optic clear A-1 Select Glass.
- (16) Weights concealed in side tubes provide life long effortless raising and lowering and revolving of glass and blanket frames.
- (17) Floor type adjustable leveling screws.
- (18) All heavy gauge steel welded construction.
- (19) Unit finished in easy to clean, long wearing Epoxy Enamel.
- (20) Unit is shipped with Top Section in separate crate to permit easy access.

Film and Plate Size	Size Inside Blanket Beading	Price with OPTION "X"	Crating	Floor Space	Height*	Approx. Crated Weight	Minimum and Maximum Printing Distance Between Frame and Lamp (measured from edge of Reflector) in one inch increments
48 x 60	51 x 63	\$22,495.00	No Chg.	54 x 96	10'2"	2300 lbs.	30" thru 48"
50 x 70	53 x 73	23,295.00	No Chg.	56 x 106	11'2"	2500 lbs.	42" thru 60"
60 x 80	63 x 83	24,875.00	No Chg.	66 x 116	11'2"	3200 lbs.	42" thru 60"
64 x 84	67 x 87	26,555.00	No Chg.	70 x 121	11'5"	3500 lbs.	42" thru 60"
52 x 100	55 x 103	28,425.00	No Chg.	56 x 137	12'	3700 lbs.	48" thru 66"

Electrical – 115 Volt, 60 hz. Single Phase A.C. Vacuum System.
220 Volt, 60 hz. Single Phase A.C. Lamp

OPTIONAL ACCESSORIES:

- (A) Douthitt Heavy Duty Model 26 Silent Air Pump instead of standard pump and motor (this pump requires compressed air) see page 27 for details..... Add \$ 395.00
- (B) Any Douthitt or Olix Combination Light Integrator and Digital Timer can be mounted in lieu of Standard Integrator Olix 975SC..... Add \$ 445.00 Details on page 10.
- (C) Violux VT8 8000 Watt Tri-Level Printing Lamp Assembly instead of standard Lamp..... Add \$1095.00
- (D) Olite AL 83 8000 Watt Tri-Level Assembly with Exhaust System instead of standard Lamp..... Add \$1500.00
- (E) Opaque Curtain – Eliminates Light Spillage. Fully fire retardant and OSHA approved material: 48 x 60-\$1095.00; 50 x 70-\$1275.00; 60 x 80-\$1295.00; 64 x 84-\$1295.00 (Curtains ordered separately add \$200.00)
- (F) Side Troughs for roll materials. (See photographs on page 16)..... Add \$3475.00
- (G) Re-registration Board or Insert Mat manufactured to your specifications Prices upon request
- (H) Electric Lift Mechanism for raising and lowering glass or blanket frame..... Add \$4195.00

DOUTHITT Elevating and Revolving Platemaker

WITH PUSH-BUTTON MOVEMENT OF YOUR PRINTING DISTANCE
REDUCES FLOOR SPACE REQUIREMENTS BY ONE HALF

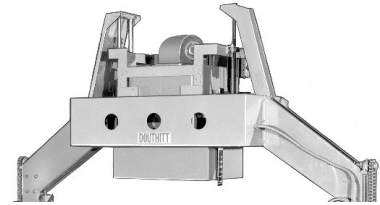

Adjustable Lamp Housing

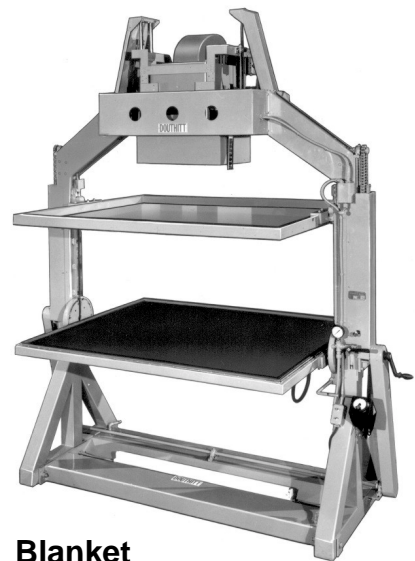

**Blanket
Down Position**

Only Douthitt has a spring loaded vacuum system allowing you to use pins of any height, pin bars or contact boards of any thickness.

DOUTHITT'S NEW VACUUM SYSTEM OPTION "X"

OPTION "X" is a controlled inverse air evacuation system which starts the evacuation of air in the center of the frame and then moves outward to the edges eliminating the trapping of air. It is over twice as fast as a conventional frame and quickly pays for itself in time saved and avoidance of remakes. Because of its absolute, consistent, repeatable electronically controlled air evacuation pattern, it will maintain better register than any other frame and will reduce your makeovers and scrap rate.

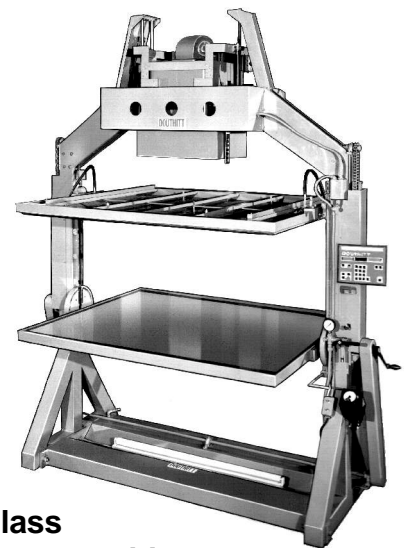

**Glass
Down Position**

DOUTHITT HEAVY DUTY VACUUM FRAME

Elevating and Revolving Model

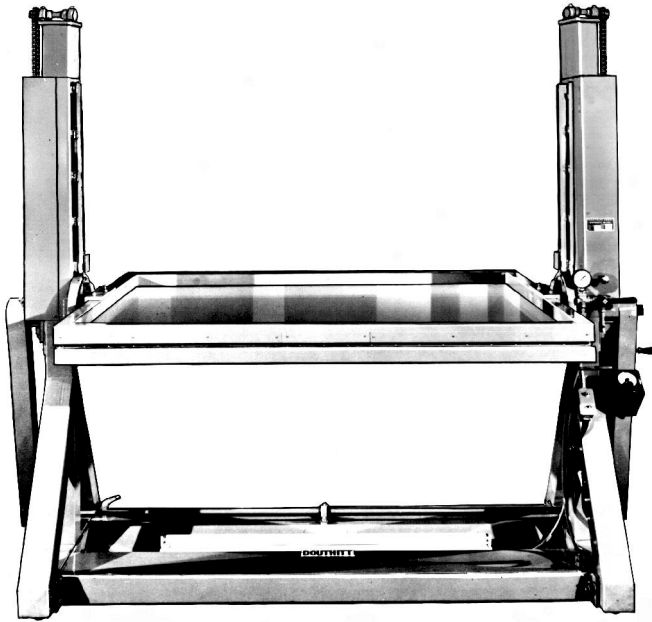

NOW STANDARD WITH OPTION "X"
FASTEST CONTACT • BEST REGISTRATION

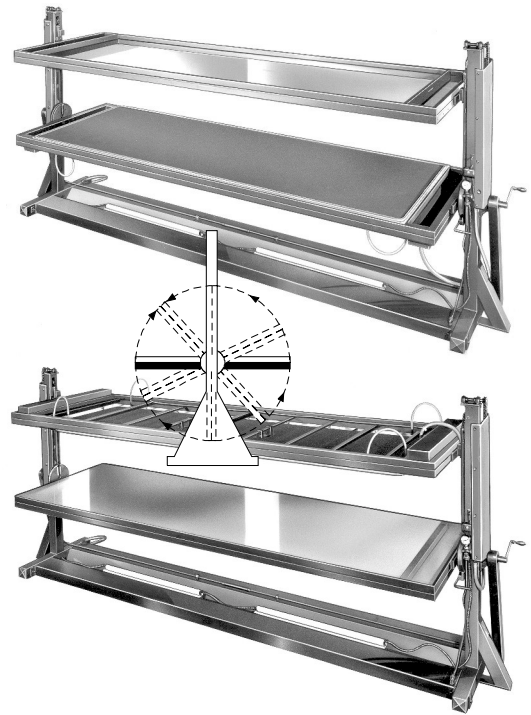

PRICE INCLUDES:

- (1) Douthitt's OPTION "X" Vacuum System. OPTION "X" gives you the fastest, most consistent overall contact and the best registration. For details see page 2.
- (2) Revolves 360° through Gyrotory Axis which Elevates, Lowers, Locks and Turns in single sweeping effortless action. See illustrations above.
- (3) Can be elevated with glass up or down.
- (4) Minimizes time spent in cleaning of glass.
- (5) Inspection Light (Gold Fluorescent) mounted in base.
- (6) Spring Loaded Back is furnished on the blanket frame allowing any heights register pins on top or thru register boards.
- (7) Heavy Duty Universal Blanket.
- (8) Heavy Duty Pump, Motor and Vacuum Gauge.
- (9) Optic clear A-1 Select Glass.
- (10) Floor type adjustable leveling screws.
- (11) All heavy gauge steel welded construction.
- (12) Unit finished in easy to clean, long wearing Epoxy Enamel.

OPTIONAL ACCESSORIES:

- (A) Douthitt Heavy Duty Model 26 Silent Air Pump instead of standard pump and motor (this pump requires compressed air) see page 27 for details..... Add \$ 395.00
- (B) Any Douthitt or Olix Combination Light Integrator and Digital Timer can be conveniently mounted on frame. MAGIC 83 Add \$870.00 Olix 975SC ... Add \$1130.00 Details on page 10. (A vacuum time delay is included with any of above integrators. Prices include PA 86 photocell.)
- (C) Side troughs for Roll materials (see photographs above) \$3125.00
- (D) Registration Board or Insert Mat manufactured to your specifications Prices upon request
- (E) Electric Lift Mechanism for raising and lowering glass or blanket frame \$4195.00
- (F) Frame may be ordered without OPTION "X" Prices upon request.

Film and Plate Size	Size Inside Blanket Beading	Price with OPTION "X"	Space Required	Crating No Chg. Weight
40x 60	43 x 63	\$12,625.00	46x 96	1250 lbs.
48x 60	51 x 63	13,245.00	54x 96	1350 lbs.
50x 70	53 x 73	13,675.00	56x 106	1450 lbs.
60x 80	63 x 83	15,195.00	66x 116	1650 lbs.
64x 84	67 x 87	17,025.00	70x 121	1800 lbs.
44x 100	47x 103	16,095.00	50x 137	1750 lbs.
54x 120	57x 123	18,975.00	60x 157	2050 lbs.
60x 120	63 x 123	20,595.00	70x 157	2250 lbs.
54x 144	57 x 147	21,475.00	60x 181	2350 lbs.
60x 144	67 x 147	23,325.00	70x 181	2550 lbs.

*SEE PAGES 2 & 3 OF THIS CATALOG FOR COMPLETE DESCRIPTION OF OPTION "X".

Custom Sizes – prices on request

Electrical Specifications – 115 Volt, 60 Cycle, Single Phase, A.C.

Special electrical requirements available on request.

DOUTHITT HEAVY DUTY VACUUM FRAME

NOW STANDARD WITH OPTION "X"
FASTEST CONTACT • BEST REGISTRATION



DOUTHITT'S NEW VACUUM SYSTEM

OPTION "X" Patented & Pat. Pending

OPTION "X" is a controlled inverse air evacuation system which starts the evacuation of air in the center of the frame and then moves outward to the edges eliminating the trapping of air. It is over twice as fast as a conventional frame and quickly pays for itself in time saved and avoidance of remakes. Because of its absolute, consistent, repeatable electronically controlled air evacuation pattern, it will maintain better register than any other frame and will reduce your makeovers and scrap rate.

MODEL DL

Rugged construction, especially designed for ease of operation and long lasting, efficient service in a production shop. **Has two printing positions:** (1) Horizontal (2) Vertical.

PRICE INCLUDES:

- (1) Douthitt's OPTION "X" Vacuum System. OPTION "X" gives you the fastest, most consistent overall contact and the best registration. For details see page 2.
- (2) Heavy Duty Vacuum Pump and Motor.
- (3) Heavy Duty Universal Blanket.
- (4) Counterbalanced sliding weights concealed in side tubes provide lifelong effortless raising of glass frame and effortless tilting of glass and blanket frames.
- (5) Spring Loaded Back is furnished on the blanket frame allowing any height register pins on top or thru register boards.
- (6) Optic clear A-1 Select Glass.
- (7) Ten Foot Service Cord.
- (8) All heavy gauge steel welded construction.

- (9) Vacuum gauge and necessary operational Switches housed on convenient instrument panel.
- (10) Floor type adjustable leveling screws.
- (11) Unit finished in easy to clean, long wearing Epoxy Enamel.
- (12) Positive locking device for perfect vacuum.

Film and Plate Size	Size Inside Blanket Beading	Price with OPTION "X"	Space Required	Crating No Chg. Weight
40 x 60	43 x 63	\$ 7,225.00	46 x 78	750 lbs.
48 x 60	51 x 63	8,045.00	54 x 78	925 lbs.
50 x 70	53 x 73	8,855.00	56 x 88	975 lbs.
60 x 80	63 x 83	10,225.00	66 x 98	1075 lbs.
44 x 100	47 x 103	10,625.00	50 x 116	1425 lbs.
52 x 100	55 x 103	11,645.00	58 x 118	1525 lbs.

Special Sizes Available on Request

Electrical Specifications – 115 Volt, 60 Cycle, Single Phase, A.C.

Special Electrical requirements available on request.

OPTIONAL ACCESSORIES:

- (A) Any Douthitt or Olix Combination Light Integrator and Digital Timer can be conveniently mounted on frame.
MAGIC 83 Add \$870.00 Olix 975SC Add \$1130.00
Details on page 10.
(A vacuum time delay is included with any of above integrators. Prices include PA 86 photocell.)
- (B) Registration Board or Insert Mat manufactured to your specifications Prices upon request
- (C) Douthitt Heavy Duty Model 26 Silent Air Pump instead of standard pump and motor (this pump requires compressed air)
(this pump requires compressed air)
see page 27 for details Add \$ 395.00
- (D) Built with Glass down and Blanket up Add \$1495.00
- (E) Reverse DL-Built to tilt toward operator (to save floor space) Add \$1525.00
- (F) Side troughs for Roll materials Add \$2795.00
- (G) Frame may be ordered without OPTION "X" Prices upon request

DOUTHITT BELLOWS PLATEMAKER

All Douthitt Platemakers Now Come Standard With OPTION "X"

PRICE INCLUDES:

- (1) Douthitt's OPTION "X" Vacuum system, an electronically controlled inverse air evacuation system that starts the vacuum in the center of the frame and moves it outward to the edges eliminating the trapping of air. OPTION "X" gives you the fastest, most consistent overall contact and the best registration. For more details on OPTION "X" see page 2.
- (2) Complete Violux VT6 6000 Watt Tri-Level Printing Lamp Assembly. Available with choice of Diazo or Multi Spectrum bulb to exactly fit your needs. For more information of the Violux and Olite printing lamps see pages 8-9.
- (3) Douthitt Heavy Duty Model Magic 83 Combination Light Integrator and Digital Timer with 10 channel memory. Integrator comes complete with vacuum time delay, PA 86 dual UV photocell. For more details see page 10.
- (4) Heavy gauge fabricated steel bellows mounted on steel track and roller bearings. This bellows moves in unison with the vacuum frame as it is raised or lowered. When in the raised printing position it eliminates all direct rays of the high actinic light source.
- (5) Lamp is adjustable as to the proper printing distance by means of a simple push-pull movement over your scale. The Lamp moves on roller bearings for effortless adjustment.



Film and Plate Size	Size Inside Blanket Beading	Price with OPTION "X"*	Patented and Pat. Pending		Approx. Crated Weight	Minimum and Maximum Printing Distance Between Frame and Lamp (measured from edge of Reflector) in one inch increments
			Crating	Floor Space**		
30 x 40	31 x 41	\$14,365.00	No Chg.	52 x 92	1150 lbs.	24" thru 36"
35 x 45	37 x 47	14,995.00	No Chg.	57 x 109	1300 lbs.	24" thru 42"
40 x 50	42 x 52	15,495.00	No Chg.	62 x 114	1450 lbs.	24" thru 42"
40 x 60	42 x 62	16,095.00	No Chg.	72 x 122	1550 lbs.	30" thru 48"
48 x 60	51 x 63	16,755.00	No Chg.	72 x 130	1650 lbs.	30" thru 48"

*SEE PAGE 2 FOR DESCRIPTION OF OPTION "X"

**Unit can be easily disassembled to fit thru a 36" door.

Electrical – 115 Volt, 60 hz. Single Phase A.C. Vacuum System.
220 Volt, 60 hz. Single Phase A.C. Lamp

OPTIONAL ACCESSORIES:

- | | |
|--|--|
| <p>(A) Douthitt Heavy Duty Model 26 Silent Air Pump instead of standard pump and motor (this pump requires compressed air) see page 27 for details.....Add \$ 395.00</p> <p>(B) Any Douthitt or Olix Combination Light Integrator and Digital Timer can be mounted in lieu of Standard Integrator
Olix 975SC Add \$ 445.00
Details on page 10.</p> <p>(C) Violux VT8 8000 Watt Tri-Level Printing Lamp Assembly instead of Standard Lamp . Add \$1095.00</p> <p>(D) Kokomo Filter Attachment for Violux Lamps Add \$295.00
with Clearing Filter Add \$235.00</p> | <p>(E) Olite AL53 5000 Watt Tri-Level Printing Lamp Assembly instead of standard lamp Add \$100.00</p> <p>(F) Olite AL83 8000 Watt Tri-Level Printing Lamp Assembly instead of standard lamp Add \$1500.00</p> <p>(G) Dual rolling filter folder with Kokomo and Clearing Filters for AL53 Add \$695.00
(For other filters for AL53 see page 9)</p> <p>(H) Registration Board or Insert Mat manufactured to your specifications Prices upon request</p> <p>(I) Spare bulb for printing lamp see pages 8 & 9.</p> |
|--|--|

DOUTHITT HEAVY DUTY EXPOSURE SYSTEM

EXCONO MODEL

Douthitt Advantages in an Economy Package

PRICE INCLUDES:

- (1) Douthitt's OPTION "X" Vacuum system, an electronically controlled inverse air evacuation system that starts the vacuum in the center of the frame and moves it outward to the edges eliminating the trapping of air. OPTION "X" gives you the fastest, most consistent over all contact and the best registration. For more details on OPTION "X" see page 2.
- (2) Complete Olite AL 53 Tri-level 5000 Watt Printing Lamp Assembly with fixed height mount. For more details on the Olite and Violux Printing Lamps see pages 8-9
- (3) Douthitt Heavy Duty Model Magic 83 Combination Light Integrator and Digital Timer with 10 channel memory. Integrator comes complete with vacuum delay, PA 86 dual UV photocell, and ability to control all 3 intensities of the printing lamps. For more details see page 10.
- (4) Spring Loaded Back is furnished on the blanket frame allowing any height register pins or contact boards of any thickness.
- (5) Opaque curtain assembly to eliminate light spillage. Fully fire retardant and OSHA approved material.
- (6) Finger Tip Control of glass frame is achieved by exclusive, patented spring and fulcrum system (clamps automatically).
- (7) Heavy Duty Universal Blanket.
- (8) Heavy Duty Vacuum Pump and Motor.
- (9) Optic clear A-1 Select Glass.
- (10) All heavy gauge steel welded construction.
- (11) Vacuum Gauge, Integrator and necessary operational switches housed on convenient instrument panel.



Film and Plate Size	Size Inside Blanket Beading	Price With OPTION "X"	Floor Space	Crating No. Chg. Weight
26 x 30	27 x 31	\$ 10,985.00	40 x 43	780 lbs.
30 x 40	31 x 41	11,385.00	44 x 53	850 lbs.
33 x 43	35 x 45	11,485.00	50 x 56	880 lbs.
37 x 48	38 x 50	11,785.00	54 x 61	930 lbs.
40 x 50	42 x 52	11,905.00	54 x 63	970 lbs.
40 x 60	42 x 62	12,355.00	54 x 73	1020 lbs.
48 x 60	50 x 62	12,735.00	63 x 74	1130 lbs.

OPTIONAL ACCESSORIES

- | | |
|---|---|
| <p>(A) Douthitt Heavy Duty Model 26 Silent Air Pump instead of standard pump and motor (these pumps require compressed air) see page 27 for details Add \$ 395.00</p> | <p>(B) 5-Drawer Ball Bearing Cabinet mounted inside tubular steel stand in lieu of standard construction.
 30 x 40 and 33 x 43 (Drawer I.D. 25 x 37) Add \$ 995.00
 37 x 48 and 40 x 50 (Drawer I.D. 32 x 43) Add \$1095.00
 40 x 60 and 48 x 60 (Drawer I.D. 32 x 43) Add \$1195.00</p> |
|---|---|

DOUTHITT'S NEW VACUUM SYSTEM OPTION "X"

Patented & Pat. Pending

OPTION "X" is a controlled inverse air evacuation system which starts the evacuation of air in the center of the frame and then moves outward to the edges eliminating the trapping of air. It is over twice as fast as a conventional frame and quickly pays for itself in time saved and avoidance of remakes. Because of its absolute, consistent, repeatable electronically controlled air evacuation pattern, it will maintain better register than any other frame and will reduce your makeovers and scrap rate.

DOUTHITT HEAVY DUTY VACUUM FRAME Console Model D

**NOW STANDARD
WITH OPTION "X"
FASTEST CONTACT •
BEST REGISTRATION**

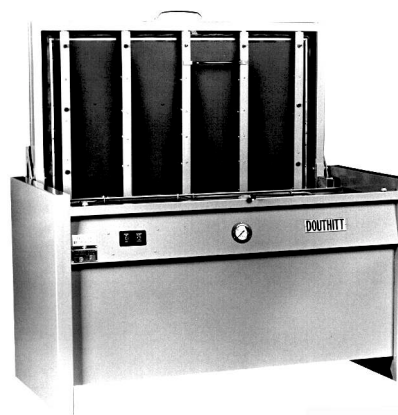
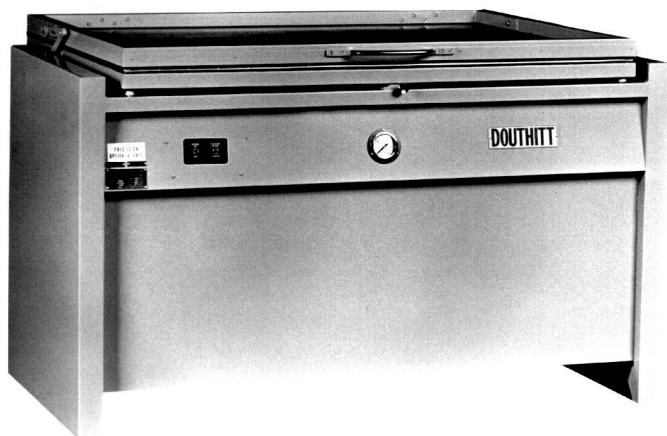

**Printing Lamps
see pages 8-9**

MODEL D

Has two printing positions (1) Horizontal (2) Vertical. Finger Tip Control is achieved through use of exclusive, patented Spring and Fulcrum System eliminating clamps, weights and heavy lifting.

PRICE INCLUDES:

- (1) Douthitt's OPTION "X" Vacuum System. OPTION "X" gives you the fastest, most consistent overall contact and the best registration. For details see page 2.
- (2) Heavy Duty Vacuum Pump and Motor.
- (3) Heavy Duty Universal Blanket.

OPTIONAL ACCESSORIES:

- (A) Douthitt Heavy Duty Model 26 Silent Air Pump instead of standard pump and motor (this pump requires compressed air) see page 27 for details..... Add \$ 395.00
- (B) Any Douthitt or Olix Combination Light Integrator and Digital Timer can be mounted in front instrument panel.
MAGIC 83 with PA 86 photocell Add \$ 870.00
Olix 975SC with PA 86 photocell Add \$1130.00
Details on page 10.
(A vacuum time delay is included with any of above integrators.)
- (C) Regristration Board or Insert Mat manufactured to your specifications Prices upon request
- (D) Frame can be ordered without OPTION "X" Prices upon request

DOUTHITT'S NEW VACUUM SYSTEM

OPTION "X" Patented & Pat. Pending

OPTION "X" is a controlled inverse air evacuation system which starts the evacuation of air in the center of the frame and then moves outward to the edges eliminating the trapping of air. It is over twice as fast as a conventional frame and quickly pays for itself in time saved and avoidance of remakes. Because of its absolute, consistent, repeatable electronically controlled air evacuation pattern, it will maintain better register than any other frame and will reduce your makeovers and scrap rate.

- (4) Glass section lifts to any position. When loaded, patented fulcrum arrangement equalizes weight of loaded frames.
- (5) Spring Loaded Back is furnished on the blanket frame allowing any height register pins on top or thru register boards.
- (6) Optic clear A-1 Select Glass.
- (7) Ten Foot Service Cord.
- (8) All heavy gauge steel welded construction.
- (9) Vacuum gauge and necessary operational Switches housed on convenient instrument panel.
- (10) Floor Type Adjustable Leveling screws.
- (11) Unit finished in easy to clean, long wearing Epoxy Enamel.

Film and Plate Size	Size Inside Blanket Beading	Price with OPTION "X"	Space Required	Crating No Chg. Weight
30 x 40	31 x 41	\$5145.00	37 x 52	500 lbs.
33 x 43	35 x 45	5575.00	41 x 56	525 lbs.
37 x 48	38 x 50	5745.00	44 x 61	575 lbs.
40 x 50	42 x 52	5875.00	48 x 63	600 lbs.
40 x 60	42 x 62	6295.00	48 x 73	700 lbs.
48 x 60	51 x 63	6695.00	57 x 74	800 lbs.

Electrical Specifications – 115 Volt, 60 Cycle, Single Phase, A.C.

Special electrical requirements available on request.

DOUTHITT HEAVY DUTY VACUUM FRAME

Wall Model—Space Saver!

Uses only six inches of floor space



Printing Lamps
see pages 8-9

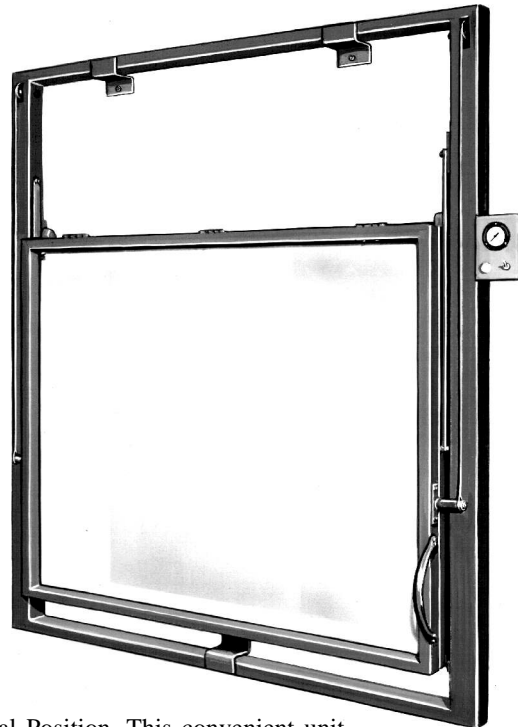

NOW STANDARD
WITH OPTION "X"
FASTEST CONTACT •
BEST REGISTRATION



WALL MODEL

Only 6" needed when in Vertical Position. This convenient unit attaches to the wall and folds down out of the way when not in use. HAS TWO PRINTING POSITIONS:

- (1) Horizontal
- (2) Vertical

PRICE INCLUDES:

- (1) Douthitt's OPTION "X" Vacuum System. OPTION "X" gives you the fastest, most consistent overall contact and the best registration. For details see page 2.
- (2) Heavy Duty Vacuum Pump and Motor.
- (3) Heavy Duty Universal Blanket (See page 46 for complete description).
- (4) Counterbalanced sliding weights concealed in side tubes provide lifelong effortless raising of glass frame and effortless tilting of glass and blanket frames.
- (5) Spring Loaded Back is furnished on the blanket frame allowing any height register pins or contact boards of any thickness.
- (6) Optic clear A-1 Select Glass.
- (7) Ten Foot Service Cord.

- (8) All heavy gauge steel welded construction.
- (9) Positive Locking Device.
- (10) Unit finished in easy to clean, rust resistant, long wearing Epoxy Enamel.

Film and Plate Size	Size Inside Blanket Beading	Price with OPTION "X"	Space Required	Crating No Chg. Weight
30 x 40	31 x 41	\$5345.00	63"	400 lbs.
33 x 43	35 x 45	5655.00	66"	450 lbs.
37 x 48	38 x 50	5845.00	72"	510 lbs.
40 x 50	42 x 52	6355.00	74"	550 lbs.
40 x 60	43 x 63	6795.00	85"	600 lbs.
48 x 60	51 x 63	7295.00	85"	650 lbs.
50 x 70	53 x 73	8555.00	90"	825 lbs.
60 x 80	63 x 83	10,275.00	100"	1050 lbs.
44 x 120	46 x 122	12,565.00	140"	1250 lbs.

*See page 2 of this catalog for complete description of OPTION "X"

Electrical Specifications – 115 Volt, 60 Cycle, Single Phase, A.C.
Special Electrical requirements available on request

OPTIONAL ACCESSORIES:

- | | |
|---|--|
| <p>(A) Douthitt Heavy Duty Model 26 Silent Air Pump instead of standard pump and motor (this pump requires compressed air) see page 27 for complete details Add \$ 395.00</p> | <p>(B) Registration Board or Insert Mat manufactured to your specifications Prices upon request</p> <p>(C) Frame can be ordered without OPTION "X" Prices upon request</p> |
|---|--|

DOUTHITT VACUUM BLANKETS

For Every Printing Frame

ALL MAKES – ALL MODELS – SIZES 16 X 20 TO 86 X 270

DOUTHITT HEAVY DUTY “SMOOTH” UNIVERSAL BLANKET

A perfect blanket for all your platemaking and contact needs. The Blanket material consists of pure rubber sandwiched between layers of a grained canvas duck. This surface will not mark your glass or indent your plates or film. Available in any length with a maximum width of 80 inches (If length exceeds 180” – Prices on request.)

PRICE – Where the narrowest O.D. (“D” dimension on print) does not exceed 52 inches, the price is 28¢ per square inch. Where it does exceed 52 inches, the price is 33¢ per square inch. No Set-Up Charge, No Crating Charge.

ANTI-STATIC PROPERTIES WOVEN INTO DOUTHITT’S SMOOTH UNIVERSAL BLANKET MATERIAL ALLOW FOR BETTER REGISTRATION.

SPECIAL FEATURE: Any section of “S” beading is easily replaceable on the Douthitt Universal Blankets. So, if you damage the beading, just order enough beading to replace the damaged section.

DOUTHITT “DEEP DRAW BLACK GUM”

For Direct Method Silk Screen Printing Frames (Textured Surface reduces drawdown time.)

Under vacuum this blanket swiftly molds itself to the shape of the silk screen frame and holds your positive in perfect contact. Available in any size.

PRICE – Where the narrowest O.D. (“D” dimension on print) does not exceed 58 inches, the price is 22¢ per square inch. Where it does exceed 58 inches, the price is 21¢ per square inch. No Set-Up Charge, No Crating charge.

NOTE: When checking your blanket dimensions, remember $A + X + Y = C$ and $B + W + Z = D$.

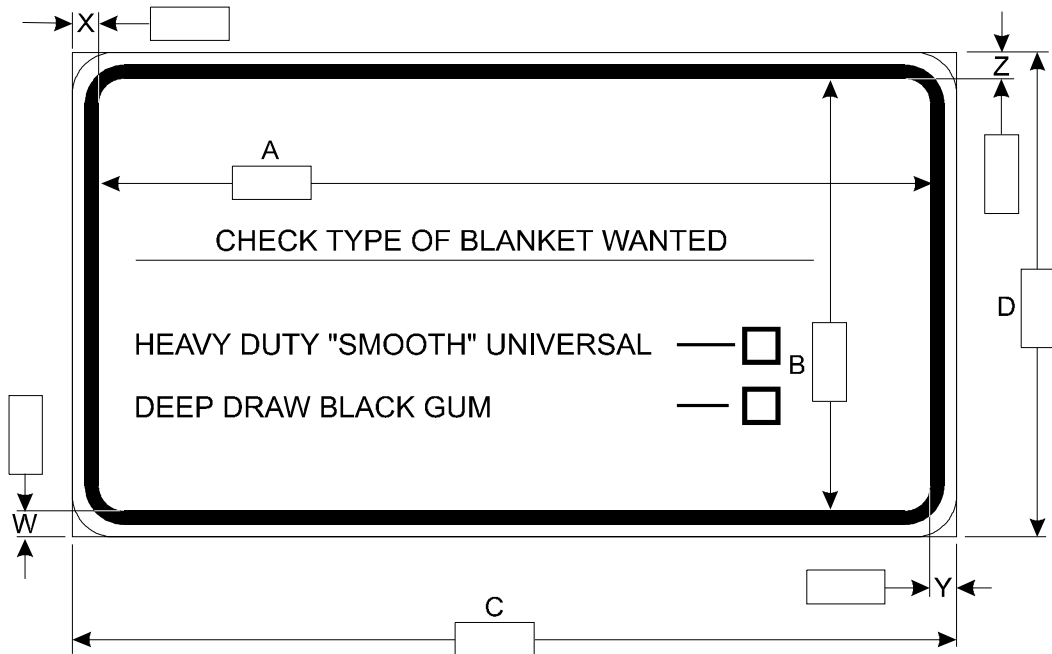

VACUUM BLANKETS DO NOT COME WITH VALVES

3/8" Blanket Valve.....\$25.45 ea.
5/8" Blanket Valve.....\$29.95 ea.

